

# Instruction Manual



 swytch

Version 003

**Got an accessory?  
Scan here for instructions.**

[www.swytchbike.com/help/manuals/](http://www.swytchbike.com/help/manuals/)



# Safety Warnings

To ensure a safe and trouble-free experience when using your Swytch Conversion Kit please follow the guidelines below:

## Kit intended use

The Swytch Kit is designed for roads and well-made paths. It's not intended for drops of more than 10cm, stunts, cross-country riding, or extreme sports. Misuse may lead to the failure of some components and void your warranty. If your Power Pack receives a significant impact, you should not continue to ride the kit, without checking the safety with a Swytch representative. The product must be used in compliance with your local laws and legislation.

## Charger warnings

The Power Pack is safe for home use, but the charger and battery will gradually and naturally heat up when it's plugged in. Do not use a previous generation of charger to charge your GO Powerpack, doing so will void your warranty. Avoid leaving your Power Pack on charge for longer than necessary as this can lead to reduced battery life. Provide adequate ventilation during charging.

**Note:** upgrade kits will not be provided with a plug, plugs can be recycled from previous generation kits and used with a new charger block.

## Power Pack warnings

Charge your Power Pack as soon as you receive your kit. Only use the Swytch charger provided to charge your Power Pack. Charge your Power Pack every 90 days whilst in storage. Read the instruction manual thoroughly to reduce the risk of injury or damage. This Power Pack must not be exposed to temperatures below -10°C or above 40°C. The battery contains dangerous substances so do not disassemble, pierce or soak in water.

Always turn off the main power button when not in use or in storage; otherwise, it will slowly drain your battery. Always mount the powerpack using 3 velcro straps. Use the buckle on each strap to tightly secure the Power Pack.

Always check after mounting that your Power Pack position does not affect the brake function of your bike. If your strap starts to fray or break, then get in touch with our team for a warranty replacement.

Always install the silicone cover to the charging port while not charging. If any water or condensation gets inside the port - you must dry the port before charging. Placing any metallic or conductive objects into the charge port other than the charger may cause electric shock, fire or other injury.

## Display warnings

GO system must **not** be used with the **Air or Max Base Display**.



### **Connector warnings**

Always remove the connector from the Power Pack while not in use or in storage. After cycling through the rain, always check if there is any water ingress in the connector or port before re-connecting. Do not install a wet connector. Only use when it's fully dry.

### **Motor Wheel warnings**

For carbon-fibre, and other types of weak/thin forks, you may need a torque arm in addition to the torque washer to safely transfer the motor torque without damaging the forks.

When fitting the axle into the forks it is essentially that it fits tightly. If there is any movement, or if the axle does not fit into the forks then you must get in touch with our support team.

**Do not attempt any modification without consent from an official Swytch Bike representative.**

### **Tighten up before riding**

Whether it's your first ride or your hundredth ride, please ensure all nuts, screws and bolts are tight before taking off on the road. Any loose parts could result in the motor wheel coming off while riding - please be careful. Every 100 km, check your wheel spokes are tight to ensure that the wheel remains secure. Refer to the maintenance section in the digital manual for more guidance.

### **Maintain your bike**

For a safe ride on any bicycle, the bike must be well-maintained and in good working order. Regularly check and maintain the condition of your bike.

### **Spares**

Only genuine replacement parts for safety-critical components must be used. There are no consumables or lubricants necessary for the Swytch Kit. Using third-party replacement parts will void your warranty. Please contact our support team for more information about spares or visit [shop.swytchbike.com](http://shop.swytchbike.com) to purchase additional items.

### **Warnings**

Throughout the manual, these callouts warn about situations that could cause serious injury and/or heavy material damage or death, if you don't follow the safety instructions.



### **Get in touch**

Before you ride your Swytch Bike for the first time, please be sure that it has been correctly assembled. For further help and support visit our help centre - [support.swytchbike.com](http://support.swytchbike.com)

**As required by the EPAC standard, the A-weighted emission sound pressure level from the Swytch kit does not exceed 70 dB(A).**

# Table of Contents

## 1

### Getting Started

---

Kit Checklist	8
Tools Required	9

## 2

### Installation

---

Motor Wheel	11
Pedal Sensor	17
Power Pack	37
Harness	41

## 3

### Know Your Kit

---

Starting Your Ride	46
Charging	47
Maintenance	48

# 1

# Getting started

Kit Checklist

Tools Required

# Kit Checklist

Use this list to get all the parts ready before you start.



Power Pack

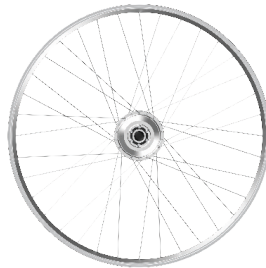

Motor Wheel

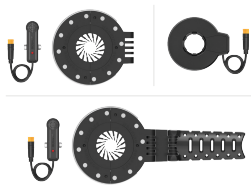

Pedal Sensor  
(your selected option)

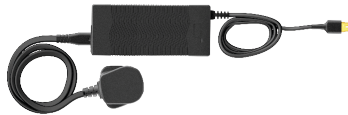

2A Charger



Harness  
(your selected length)



Cable Ties

\*Please note that this doesn't include any optional accessories.

# Tools Required

You'll need to use the following tools to install your Kit. Please note that these aren't provided.



Allen Key Set



Tyre Levers



Bike Pump



Adjustable Spanner



Ruler



Scissors



# 2

# Installation

Motor Wheel

Pedal Sensor

Power Pack

Harness

# Motor Wheel



Your Swytch motor wheel has been built to your specified size and incorporates the 250W motor hub that powers your bike. It's important that it is securely fitted into your forks.

## 1. Remove your existing front wheel

- 1.1 Turn your bike upside down. Release your brakes, then loosen your front wheel and remove it.

### Note

These steps depend on the brand and type of bike you have. If any doubts, please refer to your bike manufacturer's instructions.



## 2. Prepare your Swytch motor wheel

- 2.1 Fit your Swytch motor wheel with a tyre and inner tube using either your existing set or a new set (advised). Use tyre levers to help you.
- 2.2 Pump up the tyre to the manufacturer's suggested tyre pressure. This is printed on the sidewall of the tyre.



- 2.3 If you have disc brakes, remove the six screws and plastic spacer from the motor wheel.
- 2.4 Move the disc rotor from your old wheel onto your Swytch motor wheel.
- 2.5 Use your existing screws and hardware. The screws should have an 8mm thread length.



Ensure 2-3 Nm of torque is used.  
Visit [swytchbike.com/manual/3nm/](http://swytchbike.com/manual/3nm/) for support.

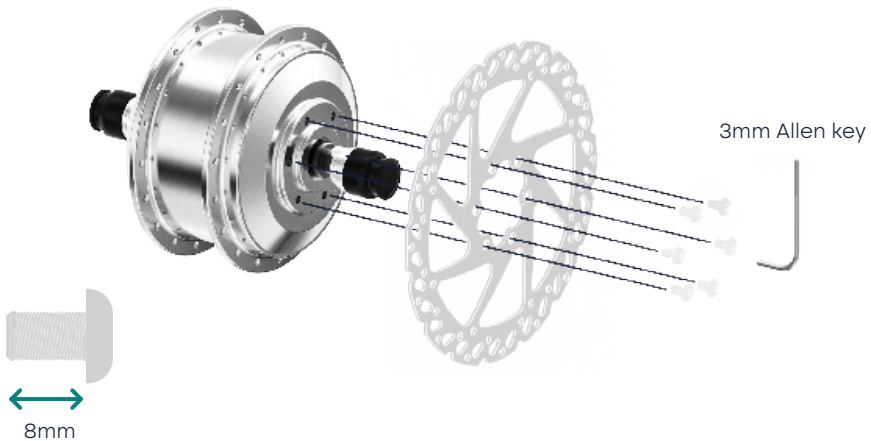

### 3. Fit the Swytch motor wheel onto your bike

- 3.1 Loosen the screws slightly and slot the Swytch motor wheel into the fork dropouts.

If you notice a gap between the axle and the forks, or if it doesn't fit tightly then please get in touch with our team for help.



The motor cable **MUST** be on the **opposite** side to the chain.



Don't file your forks to make the motor wheel fit. Contact our team for options.

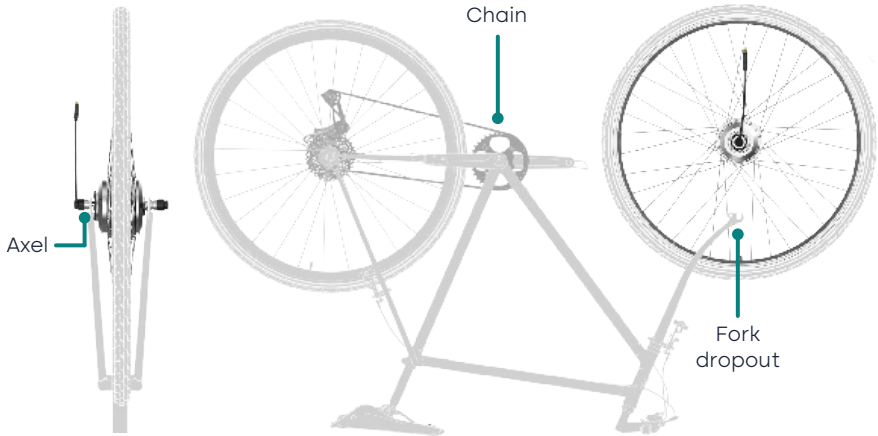

The motor cable **MUST** exit out towards the sky when the bike is **upside down**.

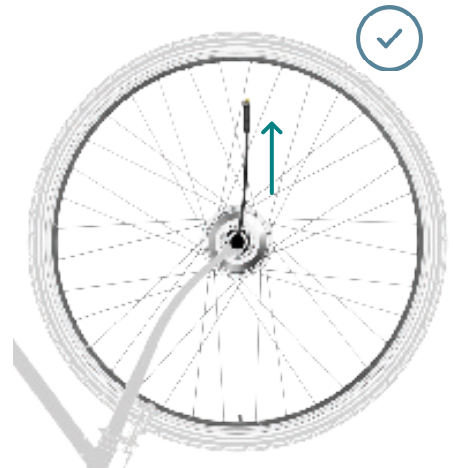
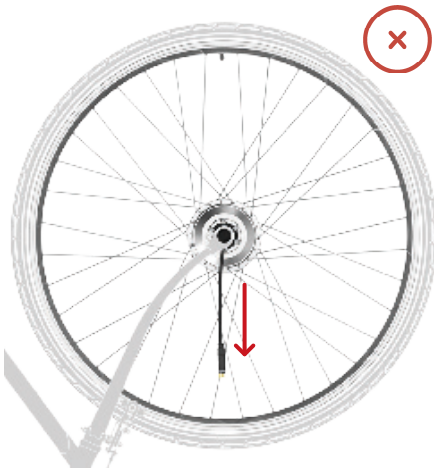

3.2 Fit the torque washer, flat washer, and axle nut as shown on **both sides of your bike**. Your bike fork dropouts should fit snugly around the lip of the torque washer.

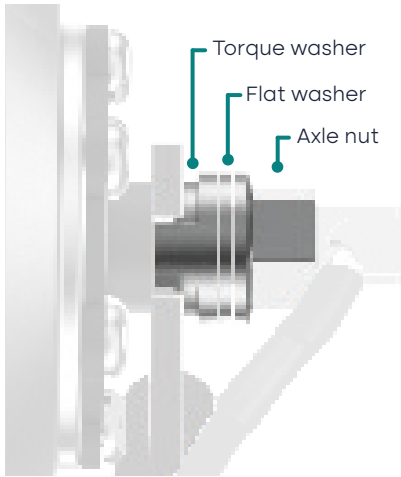

**Note**

You will have received either a 9mm or 10mm torque washer, depending on your wheel size.

**9mm**  
Torque washer

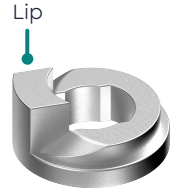

**10mm**  
Torque washer

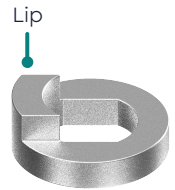

**Motor Wheel not fitting correctly?**

Check if the motor casing touches the forks. If so, widen the gap between them by adding the flat washer inside the fork.

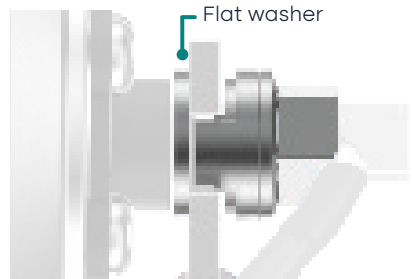

Alternatively, move the torque washer inside the fork instead of the flat washer.

The torque washer will push the forks out, so you may need to apply some pressure to seat the fork over the torque washer.

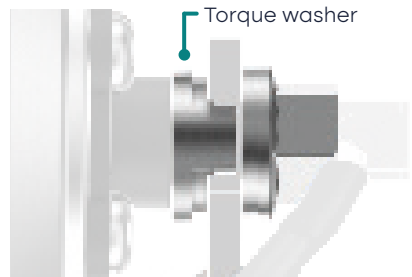

## 4. Tighten the Swytch motor wheel

- 4.1 Using a spanner tighten the nuts on both sides of the motor wheel. You'll need to temporarily take off the rubber caps to do this.
- 4.2 Place the rubber cover back over the nuts on **both sides** of the motor.

 Ensure 45 Nm of torque is used. Visit [swytchbike.com/manual/45nm/](https://swytchbike.com/manual/45nm/) for support.

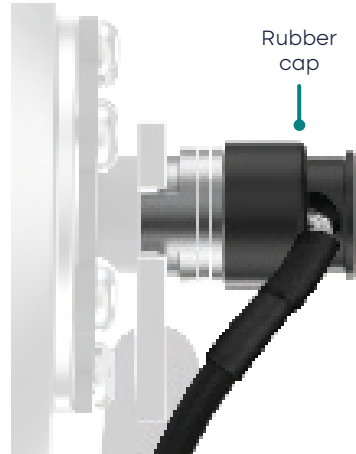
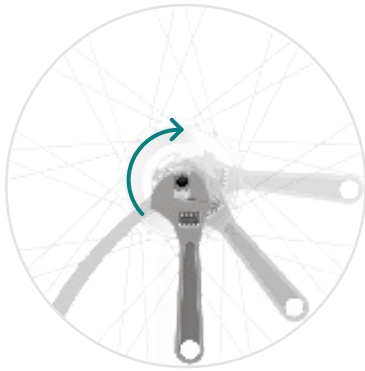

## 5. Check and adjust your brakes (if necessary)

- 5.1 Flip your bike back over.
- 5.2 If you have rim brakes, check the pads contact the new rim correctly. The brake pads should only touch the rim and not the tyre.

When adjusting the brakes, follow the bike manufacturer's instructions.

 If you're unsure about working on your brakes, visit [swytchbike.com/manual/adjustbrakes/](https://swytchbike.com/manual/adjustbrakes/) for support.

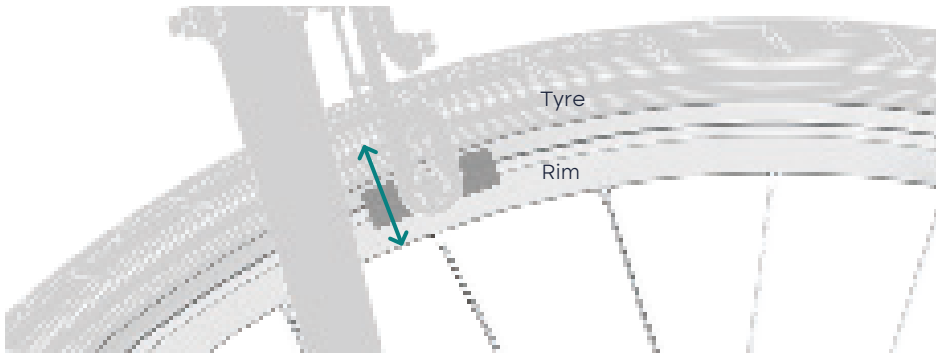

## 6. Check your motor wheel

- 6.1 Lift the front of the bike off the ground and spin the motor wheel by hand. The wheel should spin freely.



For carbon-fibre, and other types of weak forks, you may need a torque arm in addition to the torque washer to safely transfer the motor torque without damaging the forks.



When inserting the axle into the forks, ensure a snug fit. Contact our support team if there's any looseness or fitting issue. Don't modify without approval from a Swytch Bike representative.

# Pedal Sensor

The sensor is used to detect when you're pedalling.

Depending on what pedal sensor option you selected in your order portal, check the table below to find which page to find instructions to fit.

## Standard Pedal Sensor

Page 17 (next page)

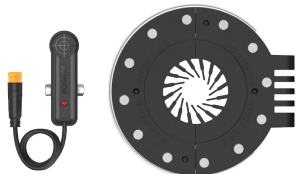

## Universal Pedal Sensor

Page 23

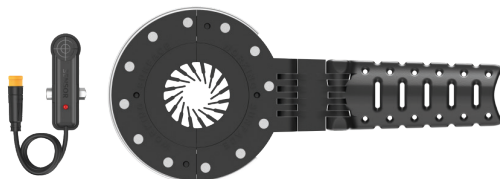

## Integrated Pedal Sensor

Page 32





## Standard Pedal Sensor

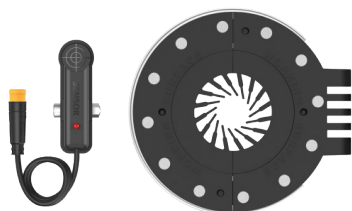

A standard 2-piece magnetic disc, suitable for most standard cranks (e.g. square taper) and a pedal sensor.

## What's included:

Pedal sensor:



Magnetic disc:

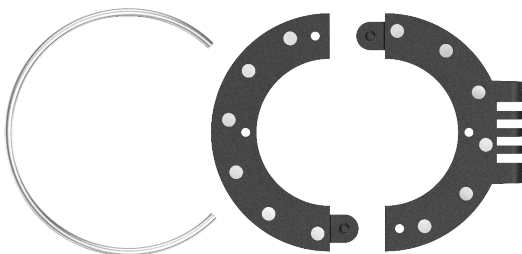

Retention ring

Magnetic disc

Inserts provided:

Easy-fit **regular** inserts (2 pieces)

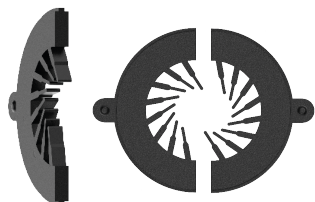

# 1. Determine if you need the inserts for your bike

- 1.1 Use a ruler to measure the gap between the end of the pedal arm and the bottom bracket shell on the non-drive side of the bike (opposite side to the chain).

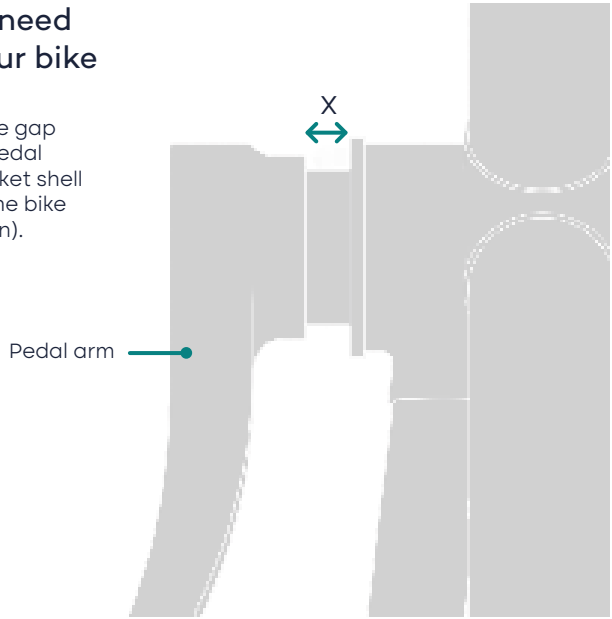

# 2. Check the table below

- 2.1 Use this table to calculate which configuration you'll need for your bike.

**Note**

If the gap is 4mm or less you may need to order a universal sensor, contact support for help.

x - Distance Between Pedal Arm and bottom bracket shell	Configuration
2mm or less	Try using the easy-fit regular inserts. If it does not fit, contact support for help.
2mm - 4mm	Try using the easy-fit regular inserts. If it does not fit, contact support for help.
4mm or more	Magnetic disc <b>with</b> Easy-fit regular inserts 

### 3. Fit the magnetic disc

3.1 Slot the magnetic disc around the crank axle, behind the pedal arm, on the side of the bike opposite the chain.

3.2 Push and click together the two halves of the magnetic disc. It should be a snug fit.

**Check the side of the disc with 'Working Surface' written is facing the bike frame.**

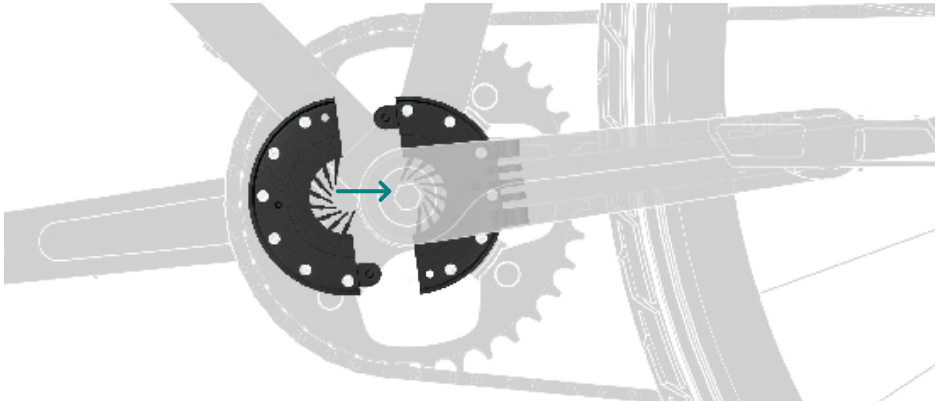

### 4. Fit the retention ring

4.1 Slide the retention ring around the magnetic disc to secure the two sides in place.

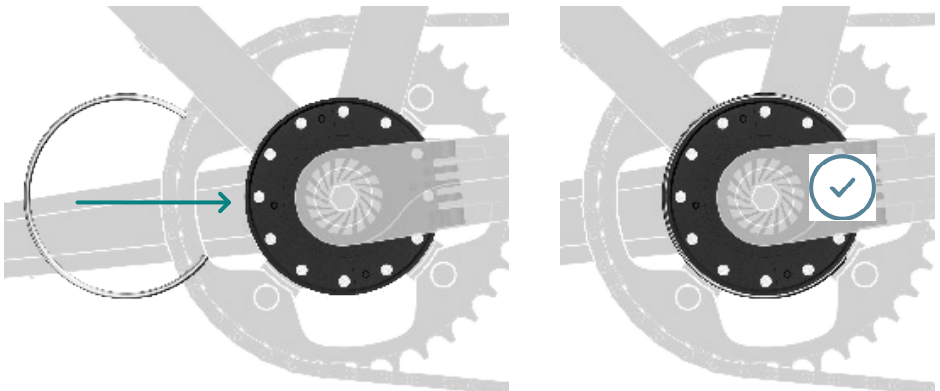

## 5. Check the alignment

- 5.1 The magnetic disc should run parallel to the frame. Check the alignment by rotating the pedal arm backwards and watch for any movement.

### Note

If the magnetic disc slides around when rotating the arm you may need to use the easy-fit regular inserts or contact support for a universal pedal sensor magnetic disc.

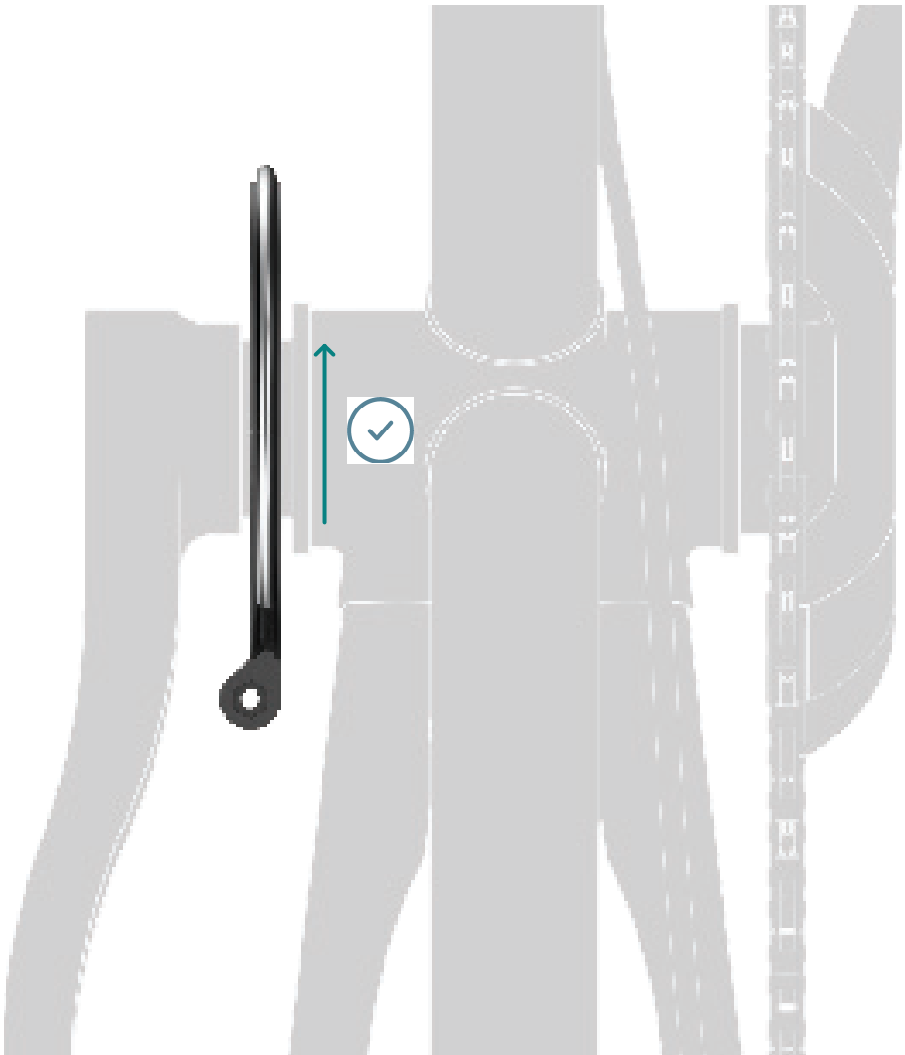

## 6. Line up the pedal sensor, stick and secure

- 6.1 Peel back the red sticker to show the adhesive layer on the back of the pedal sensor.
- 6.2 Stick the pedal sensor to the side of your down tube or seat tube.
- 6.3 Ensure the centre of the pedal sensor is aligned with the magnets on the disc.
- 6.4 Place foam adhesive spacers as required to position the sensor within 3mm of the magnetic disc.
- 6.5 Loosen the bolt to angle the sensor, then tighten and cable tie in place.

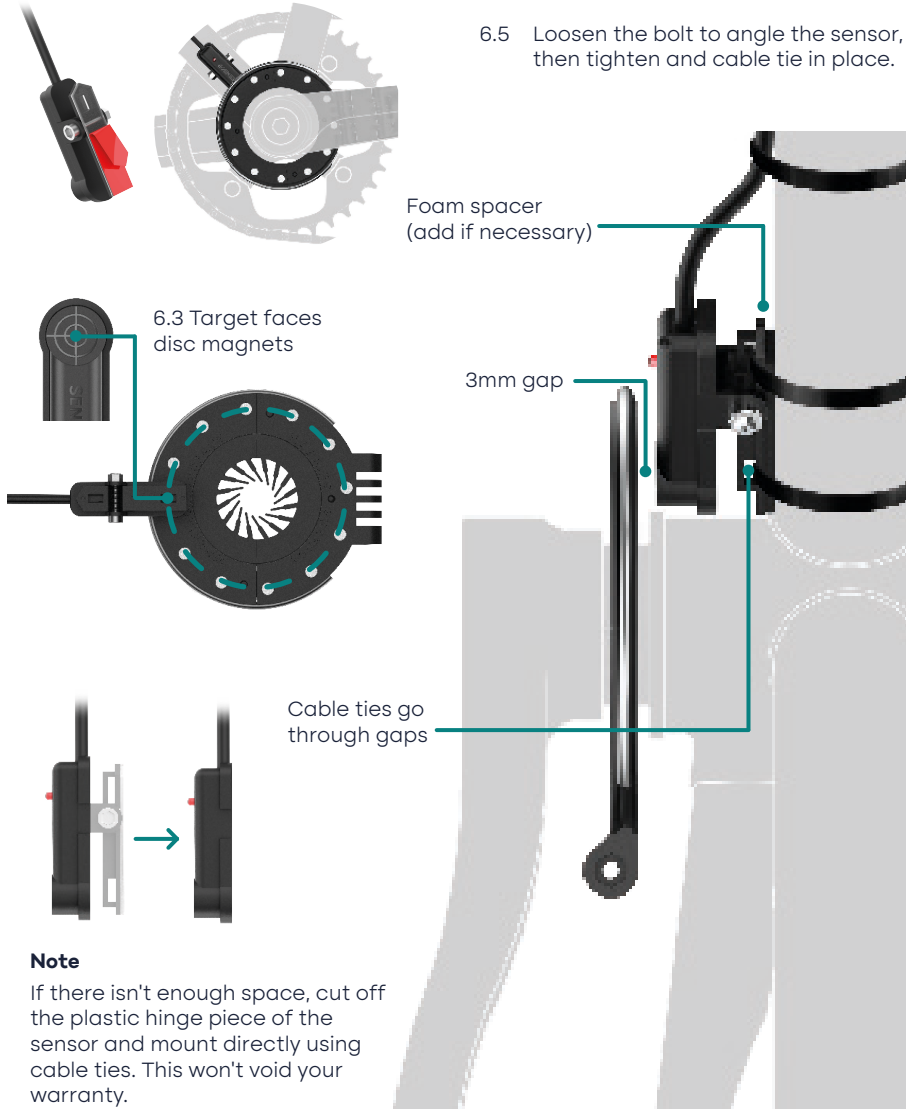

## 7. Finished

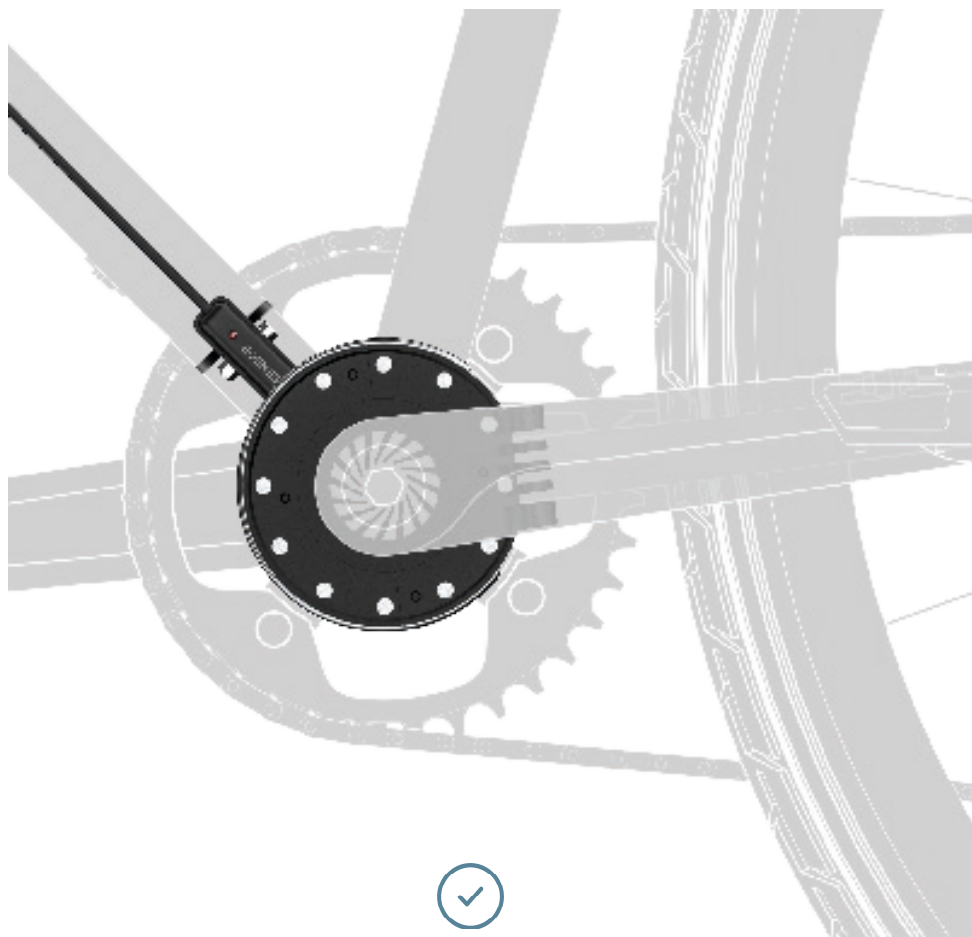

## Universal Pedal Sensor

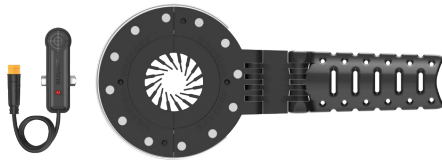

A universal 3-piece magnetic disc and pedal sensor, suitable for ANY crank.

### What's included:

Pedal sensor:



Magnetic disc regular:

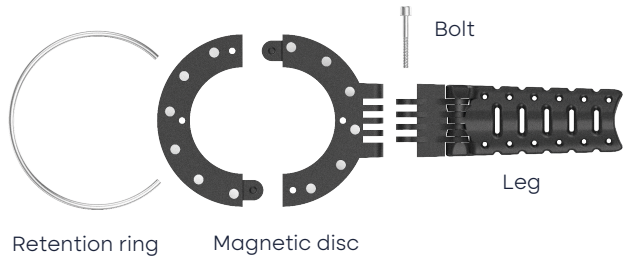

Inserts provided:

Easy fit regular **inserts** (2 pieces)

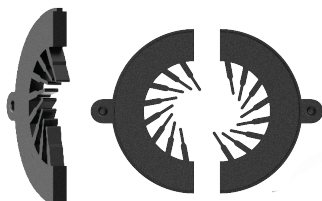

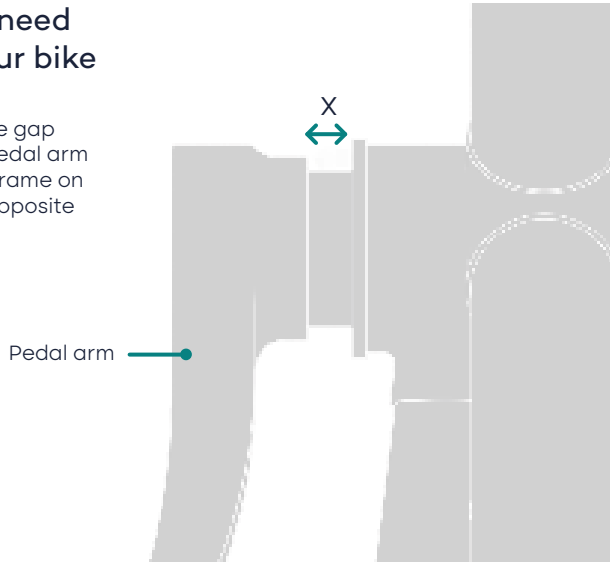

# 1. Determine if you need the inserts for your bike

- 1.1 Use a ruler to measure the gap between the end of the pedal arm and the start of the bike frame on the left side of the bike (opposite side to the chain).



# 2. Check the table below

- 2.1 Use this table to calculate which configuration you'll need for your bike.

x - Distance Between Pedal Arm and Frame	Configuration
4mm or less	Magnetic disc regular <b>without</b> inserts 
4mm or more	Magnetic disc regular <b>with</b> Easy fit regular inserts 



### 3. Fit the correct inserts (if necessary)

- 3.1 Fit together the inserts with the female parts of the magnetic disc arm. The inserts can slot in facing either orientation, but ensure the spiral of the teeth aligns as shown.

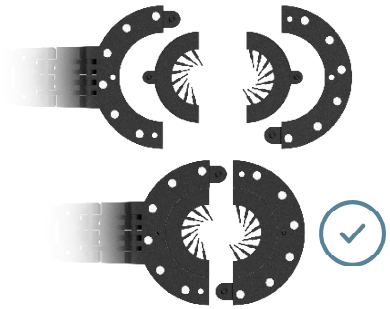

### 4. Determine if you need to flip the leg of the magnetic disc

- 4.1 Check which pedal arm your bike has from the two options below.

#### A. Round or flat pedal arm

The backside of your pedal arm is flat or round.

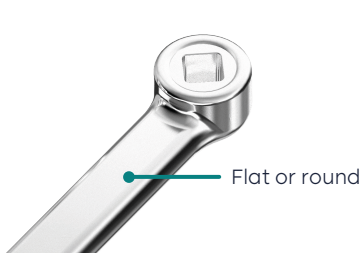

The magnetic disc leg comes ready to fit round or flat pedal arms (A) like shown so **skip to step 6**.

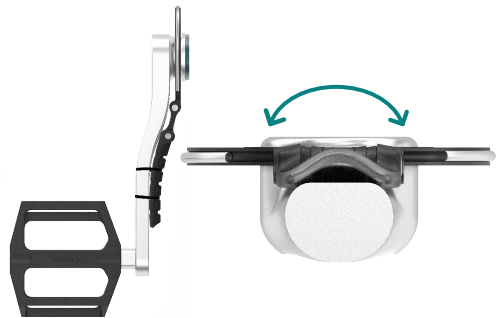

#### B. Indented pedal arm

The backside of your pedal arm has a concave indentation.



**See step 5** on the next page for instructions on how to get a better fitment.

## 5. Flip the leg of the magnetic disc (indented pedal arms only)

- 5.1 Unscrew the bolt using a 2.5mm Allen key. Take out the bolt and the leg.

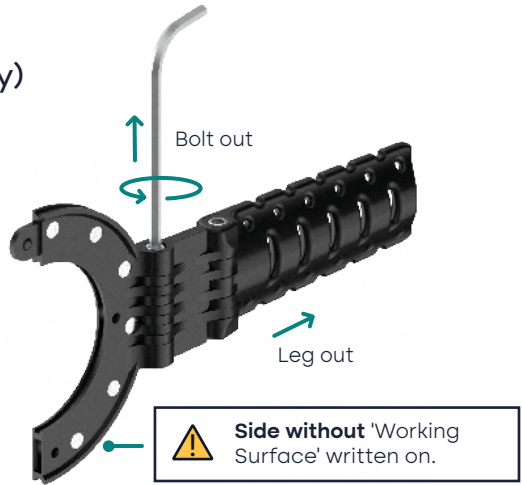

- 5.2 Flip the leg 180 degrees to match image.

- 5.3 Fit back the leg then screw and retighten.

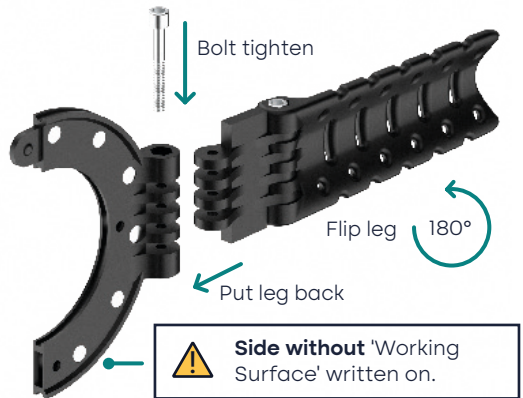

- 5.4 Check that the contour of the leg now will align with the concave indentation of the pedal arm, providing a tight fit.

**You are now ready to fit the magnetic disc to your bike.**

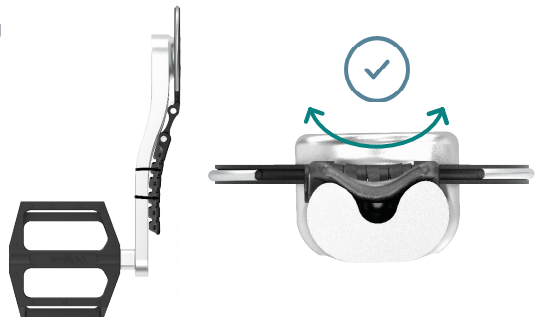

## 6. Fit the magnetic disc

- 6.1 Slot the magnetic disc around the crank axle, behind the pedal arm, on the side of the bike opposite the chain.

**Check the side of the disc with 'Working Surface' written is facing the bike frame.**

- 6.2 Push and click together the two halves of the magnetic disc.

### **Note**

If you have inserts, the same instructions apply.

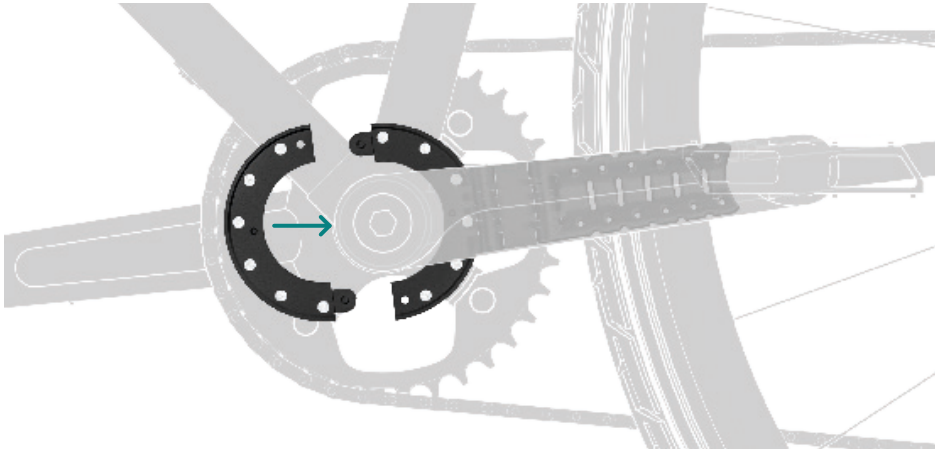

## 7. Fit the retention ring

- 7.1 Fit the retention ring around the magnetic disc to secure the two sides in place.

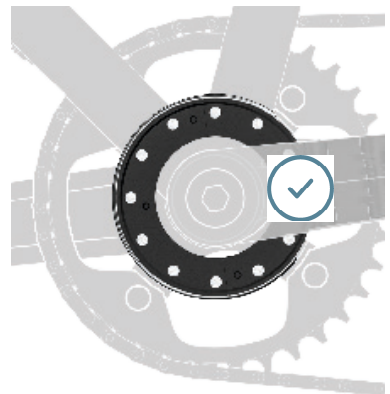
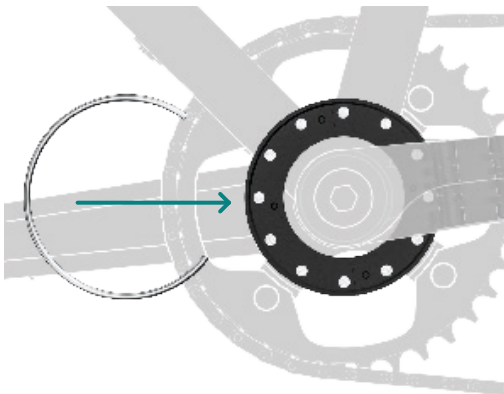

## 8. Secure the arm with cable ties

- 8.1 Slightly tighten cable tie the magnetic disc arm to the inside of your pedal arm in at least two places.

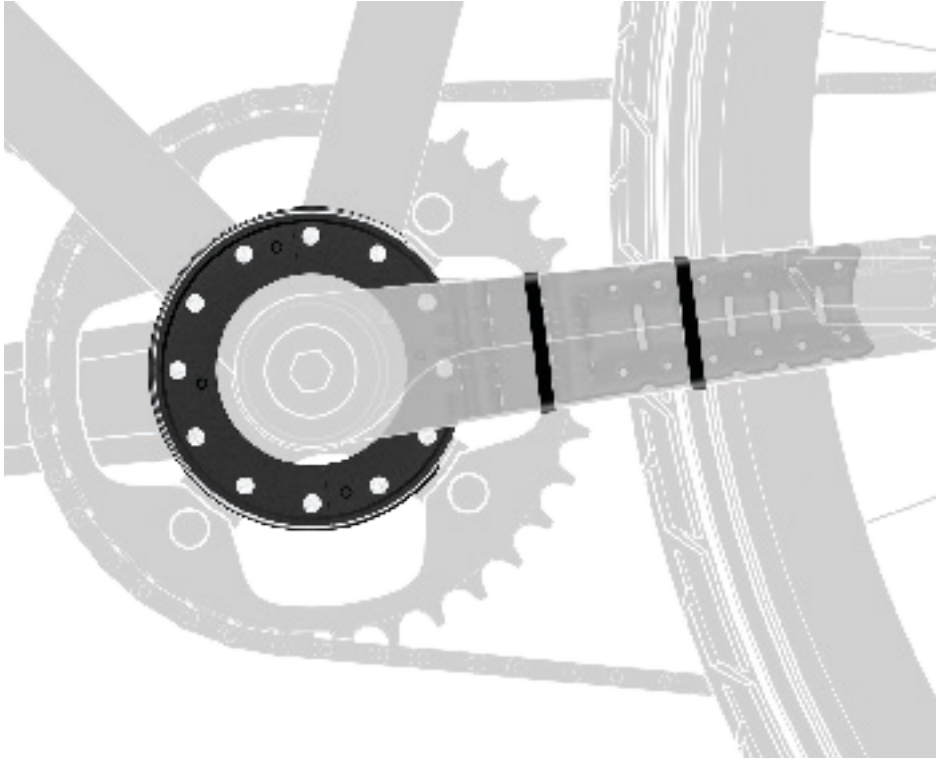

### Note

For narrow pedal arms, thread the cable ties through the holes to improve and tighten the grip.

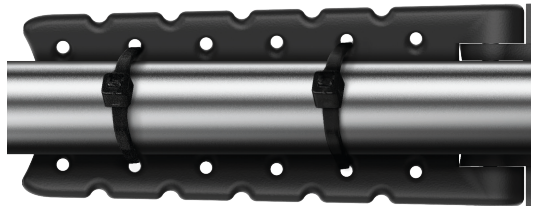

## 9. Check the alignment

9.1 The magnetic disc should run parallel to the frame. Check the alignment by rotating the pedal arm backwards and watching for any movement.

9.2 Once the alignment is correct, tighten the cable ties and bolts.

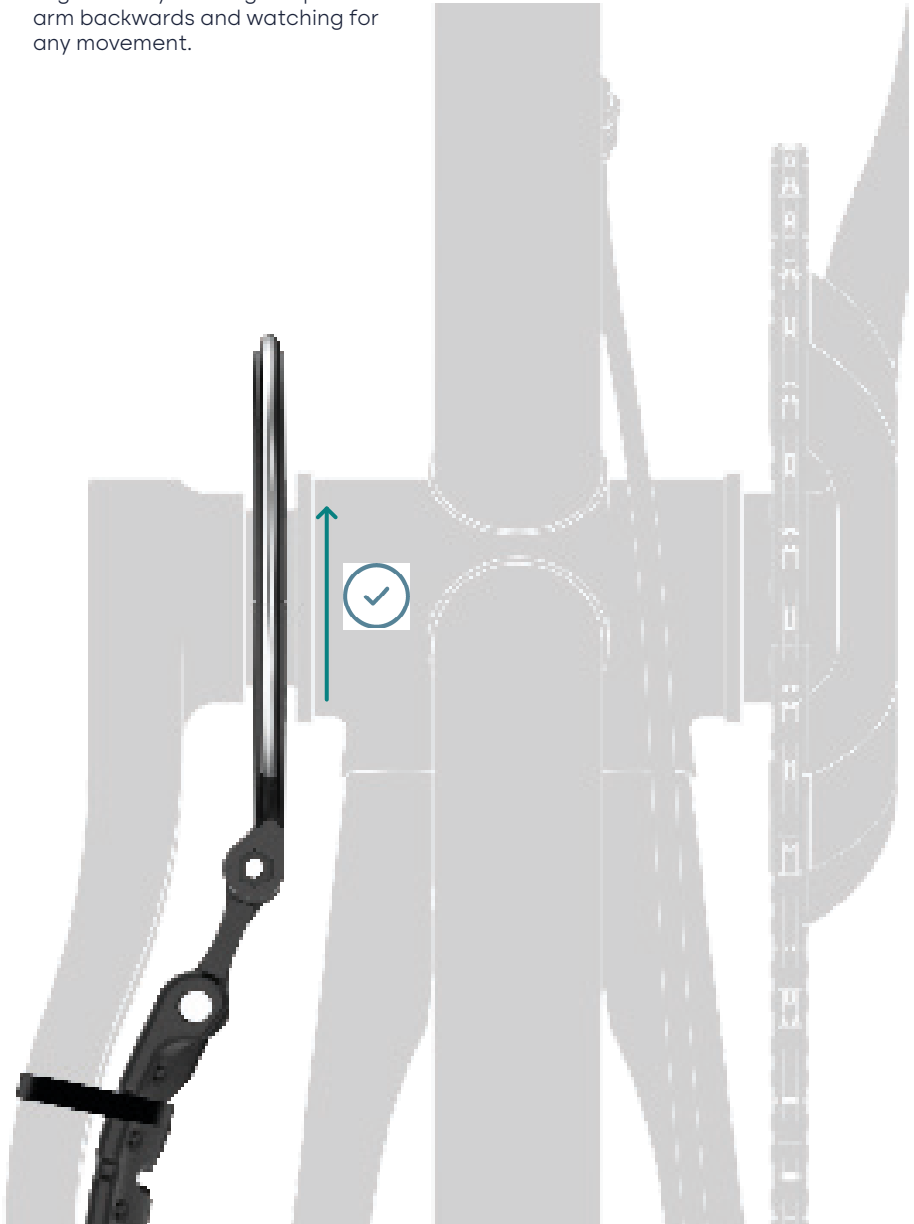

## 10. Line up the sensor, stick and secure

- 10.1 Peel back the red sticker to show the adhesive layer on the back of the sensor.
- 10.2 Stick the sensor to the side of your down tube or seat tube.
- 10.3 Ensure the centre of the sensor is aligned with the magnets on the disc.
- 10.4 Place foam adhesive spacers as required to position the sensor within 3mm of the magnetic disc.
- 10.5 Loosen the bolt to angle the sensor, then tighten and cable tie in place.

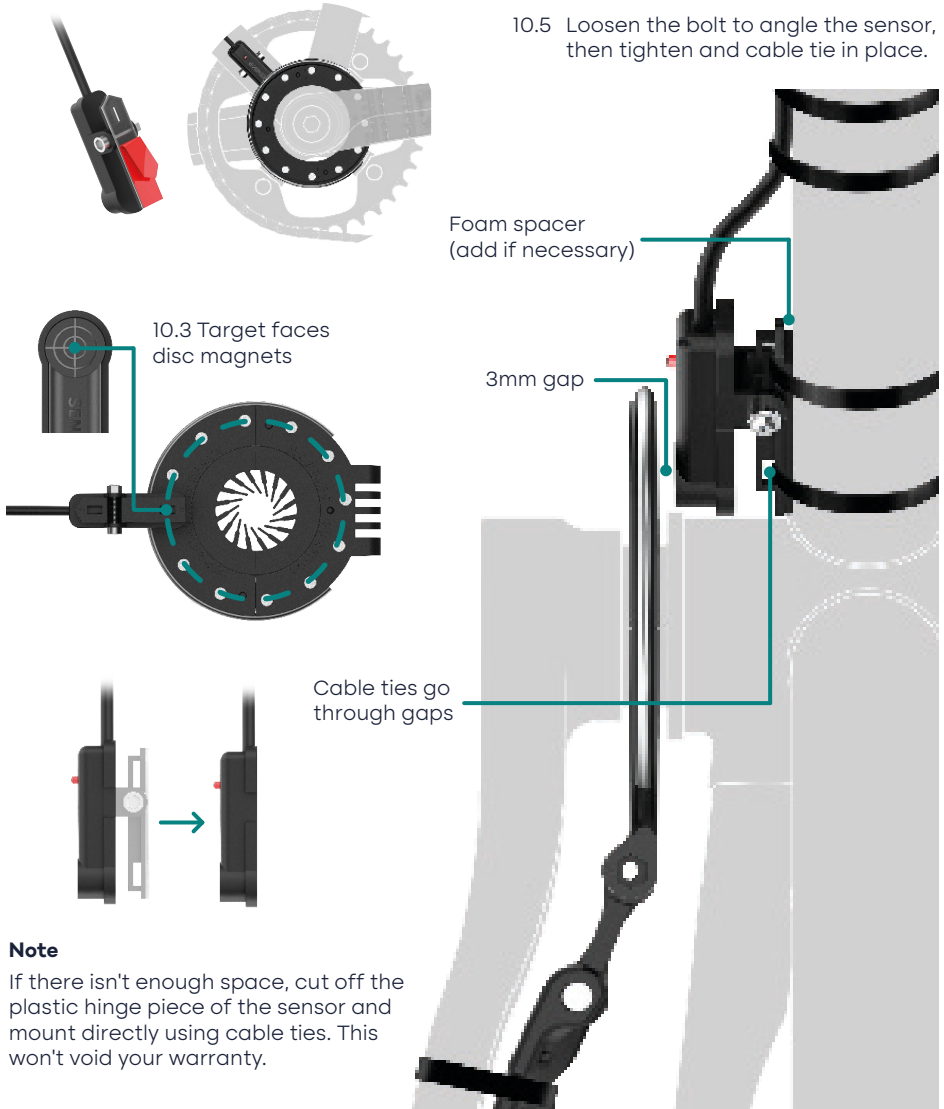

## 11. Finished

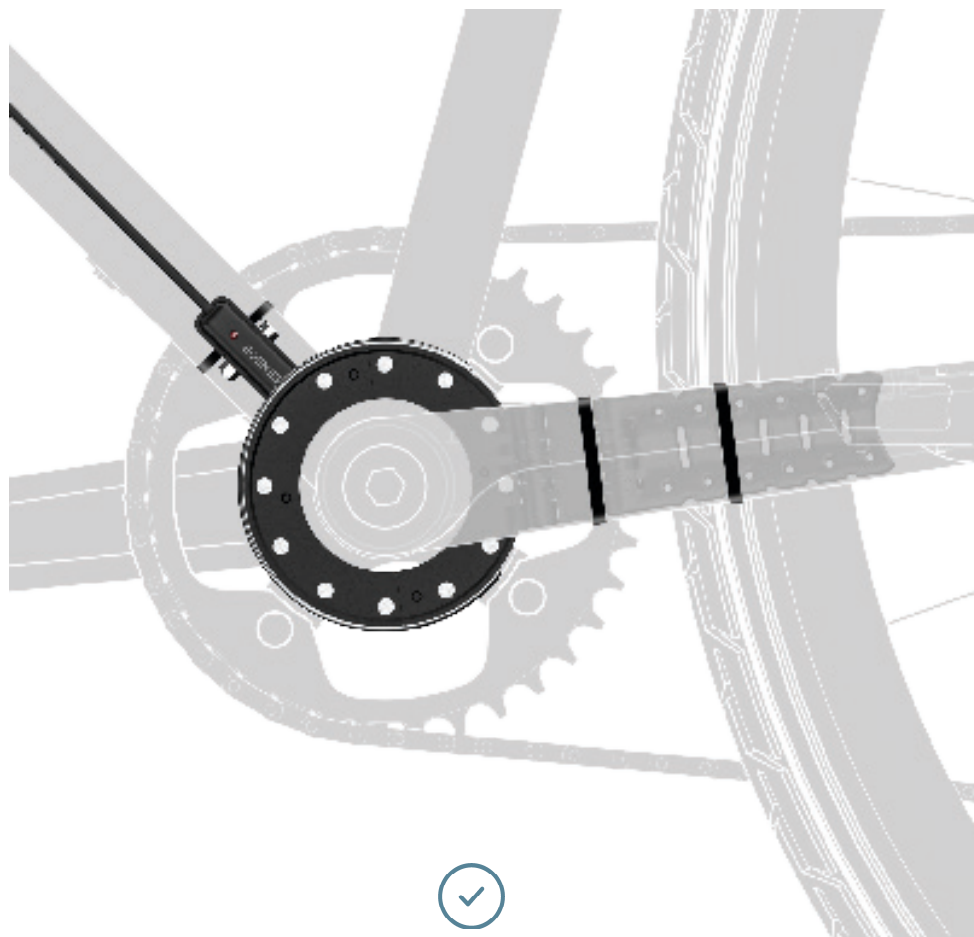

## Integrated Sensor

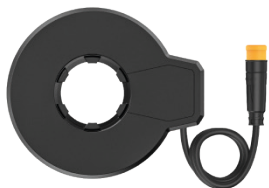

Integrated sensor for standard cranks (e.g. square taper). It requires the pedal arm to be removed and replaced for installation and the bottom brackets to have 20 splines.

### You will need:

Either 8mm Allen Key or 14mm socket



Crank extractor



## 1. Check you have space to install it

- 1.1 Use a ruler to measure the gap between the end of the pedal arm and the start of the bike frame on the left side of the bike (opposite side to the chain). The gap needs to be bigger than **4mm**.

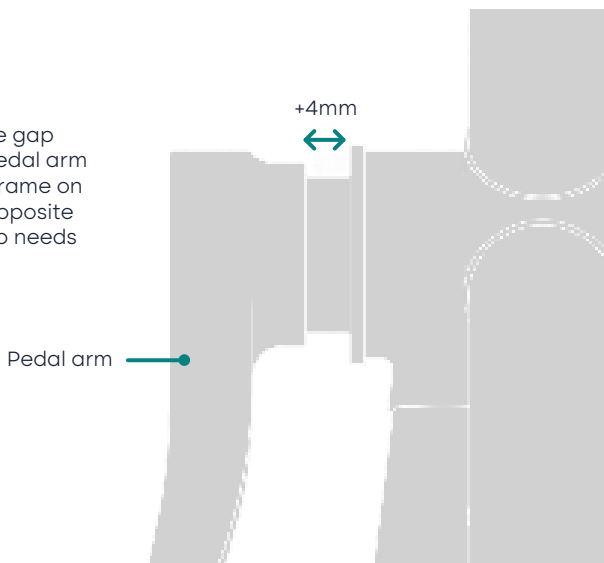



## 2. Unscrew the crank arm's bolt

- 2.1 Use the Allen key or socket to remove the bolt from the crank, working on the side opposite to the chain.

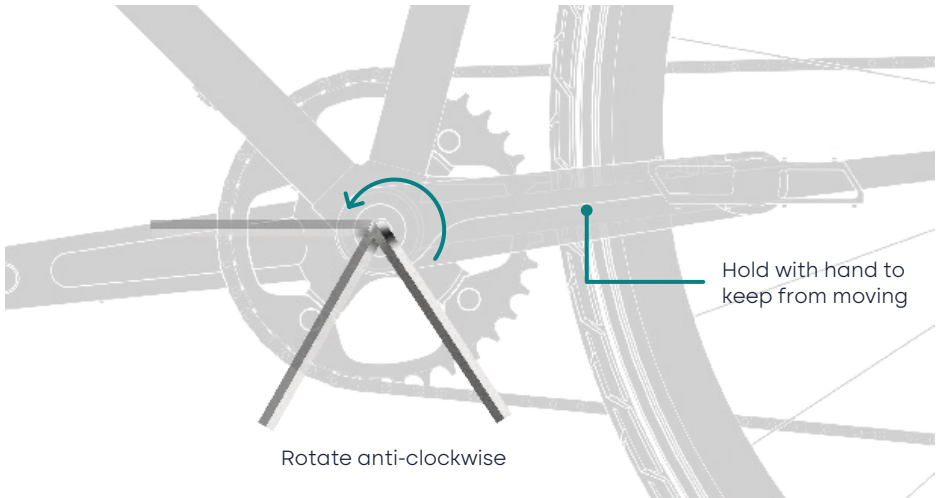

## 3. Tighten the crank extractor bolt

- 3.1 Rotate the crank extractor's bolt clockwise until it is securely tightened. Use your other hand to block the crank from spinning.

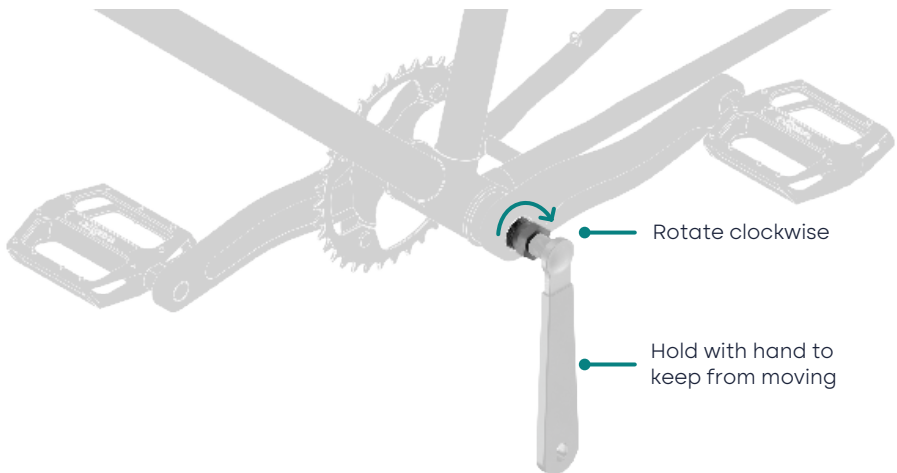

## 4. Rotate the extractor and remove the crank arm

- 4.1 Rotate the handle of the crank extractor clockwise and then remove the arm.

**Note**

This often takes quite a lot of force to rotate.

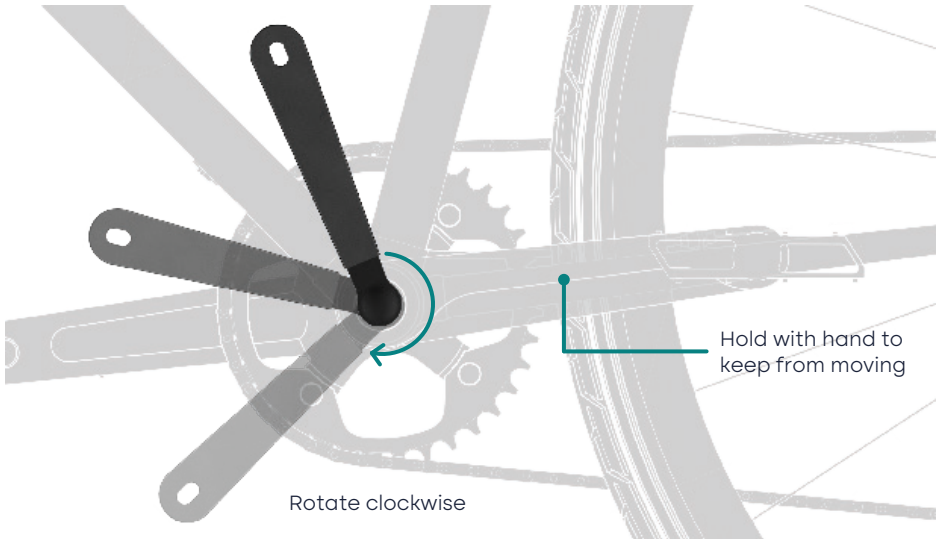

## 5. Fit the integrated sensor

- 5.1 Slide the integrated sensor fully onto the shaft onto the bottom bracket, ensuring the cable points left and towards the frame.

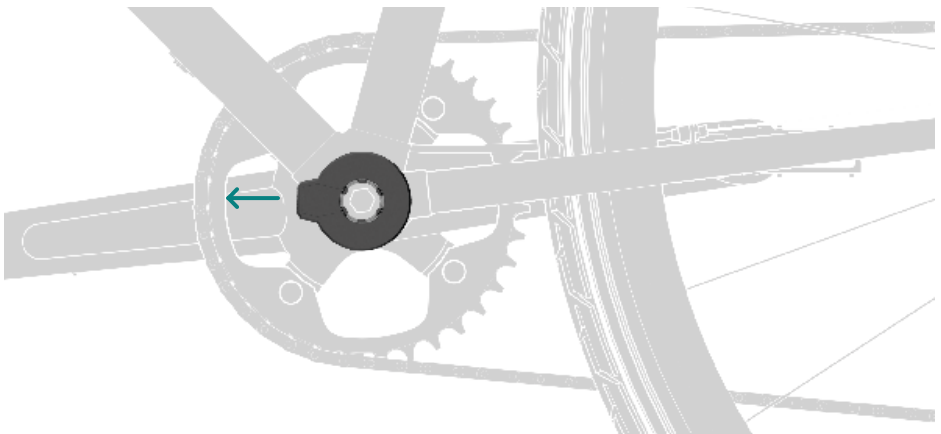

## 6. Reinstall the crank

6.1 Identify the correct position to reinstall your crank and slot it back on.

6.2 Reattach the original bolt and tighten using the Allen key to the manufacturer's torque specification.

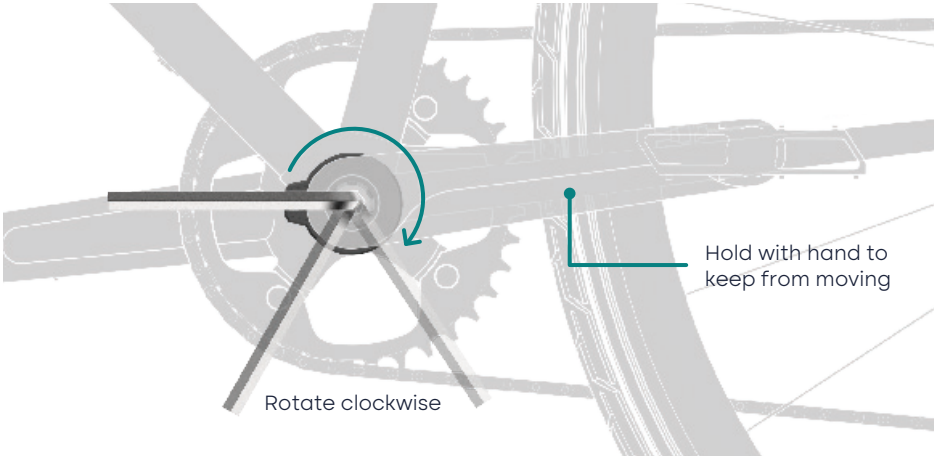
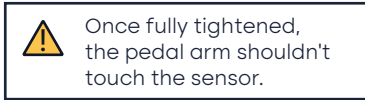

## 7. Finished

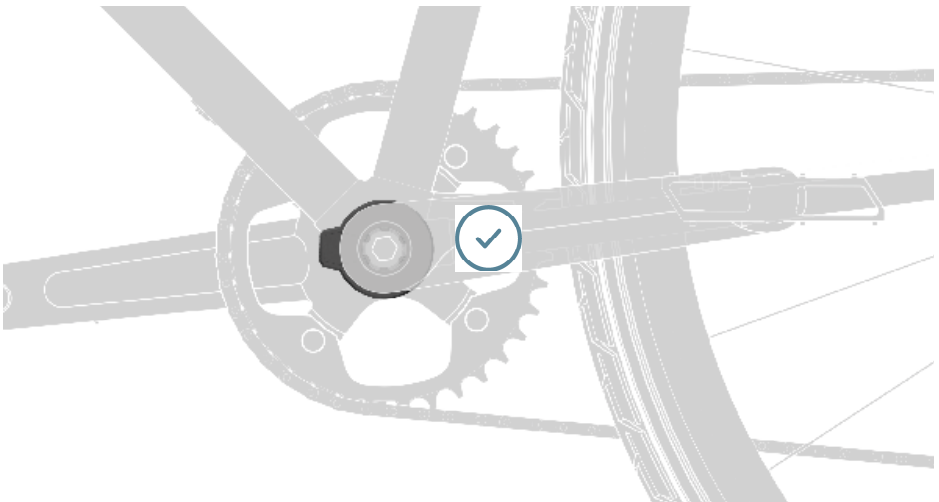

## Power Pack

This is the Swytch GO Power Pack. It has Li-ion cells inside that provide the energy for the Kit.

Swytch GO comes in three different capacities: GO 180Wh, GO+ 280Wh and GO++ 370Wh.



The battery contains dangerous substances, don't disassemble, impact or soak in water. Doing so will void your warranty.



The Power Pack shouldn't be exposed to temperatures below -10°C or above 40°C.

# 1. Determine where you wish to fit your Power Pack

- 1.1 Decide where to fit your Power Pack on your bike, considering whether you chose the standard or long connector harness.

**Note**

Don't block the connector port by facing it into the frame.

**Standard**

Our standard connector harness allows you to position the Power Pack within the frame.



**Long**

Our long connector harness is only required to mount the Power Pack in any of the positions in the image below.



## 2. Secure the Power Pack

- 2.1 Secure your Power Pack to your desired location on your bike by using the three velcro straps.

Use the buckle on each strap to secure the Power Pack.



Three straps must be used to secure it properly.



Check your brakes continue to function as normal.



Loop the strap through the buckle

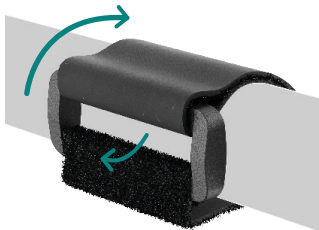

## 2. Cut the straps to size

- 2.1 Trim the three straps with scissors to eliminate any overlapping material.



Ensure that the strap has enough length to be securely fastened to your bike's frame.

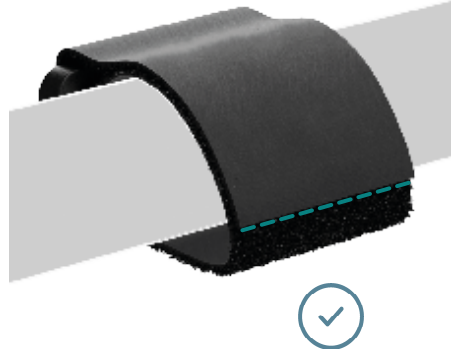
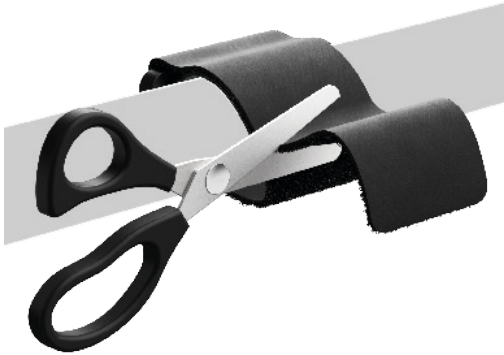

## 3. Apply protective stickers (optional)

- 3.1 To minimise the chance of damaging your bike's paint, affix the clear protective stickers provided anywhere under where the Power Pack makes contact with the frame.

### Note

Should you notice notable wear on the tape, it ought to be replaced.

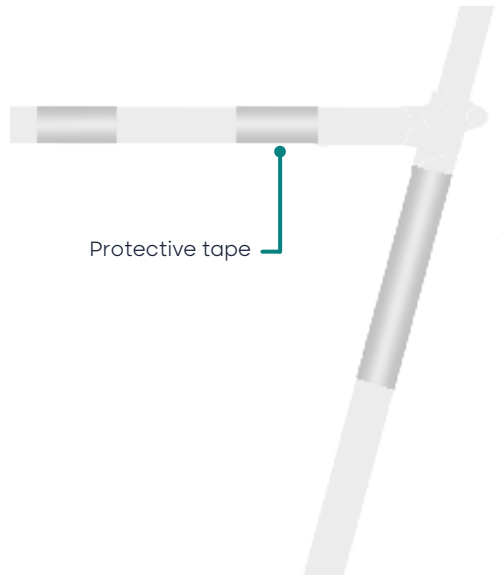

# Harness

The harness connects the Power Pack to the Swytch Kit system, it has five connectors coming out of it all with a different purpose.

## Note

The harness comes with a pre-installed no display dongle for display-free operation, as well as a throttle cap. If you have purchased a display or throttle, just unplug these and plug in the display/throttle.

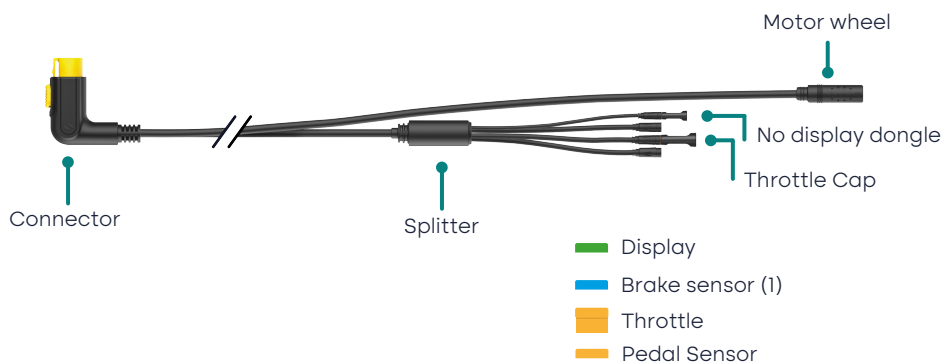

## 1. Connect the harness

- 1.1 Push the connector of the harness into the connector port on the Power Pack. No yellow should be showing on the connector end.

## Note

To remove the harness, press down on the yellow button and remove.





## 2. Connect the pedal sensor to the harness

- 2.1 To connect the waterproof connector, find the arrow on each connector and align. Once the arrows are lined up, push together until no colour is visible.

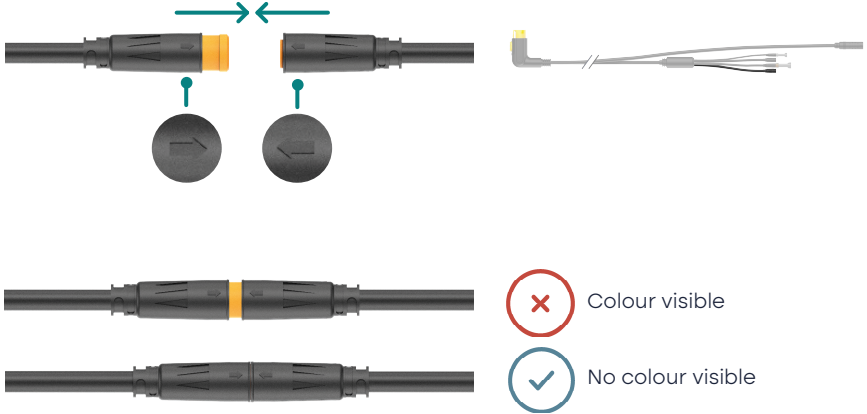

## 3. Connect the motor cable to the harness

- 3.1 To connect the waterproof connector, align the arrows and push together until the arrows touch and align on both ends.

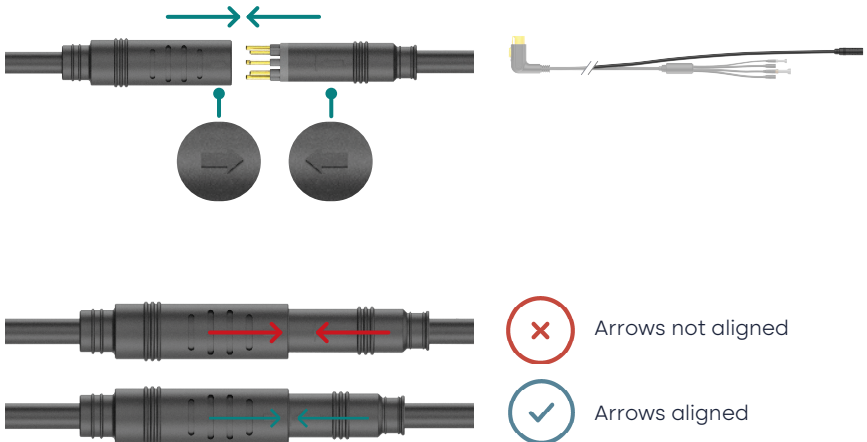

## 4. Route the harness and cables

The diagrams below illustrate different cable routings for Power Pack placement options. Please follow the diagrams when routing your cables.



Ensure the cable routing doesn't affect any part of the bike's drive train, steering or pedalling.

### Standard

Route the cables via the shortest path to the bike's headtube, where the splitter should be positioned. The motor cable should run down the fork.

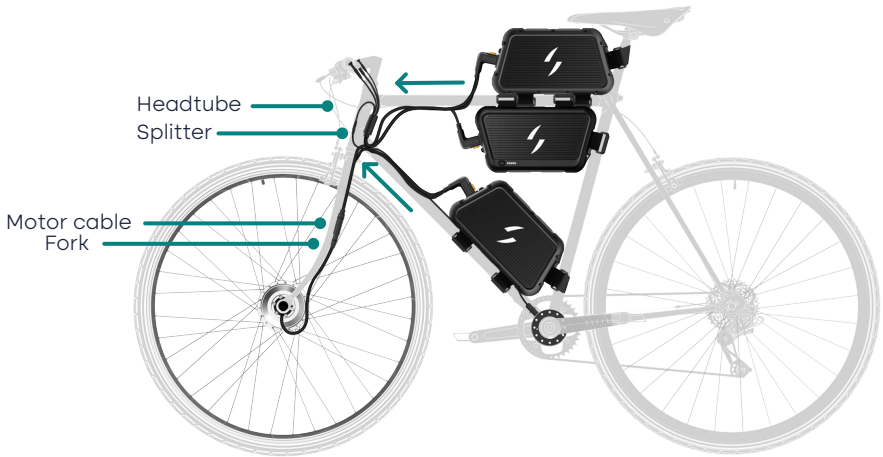

### Long

Route the cables to the bike's headset utilising as much cable as possible. This is where the splitter should be positioned. The motor cable should then follow down the fork.

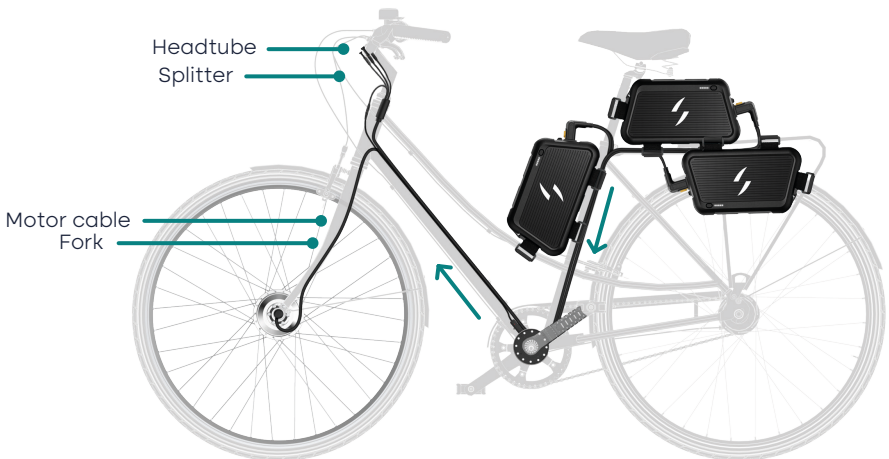

## 5. Secure the harness and cables

- 5.1 Secure all cabling to the frame of the bike using the cable ties that were provided.

### Note

Follow the existing cable routing of your bike.

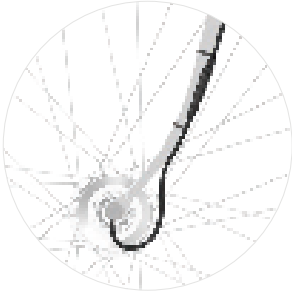

Securely attach the motor cable to the bike's fork.

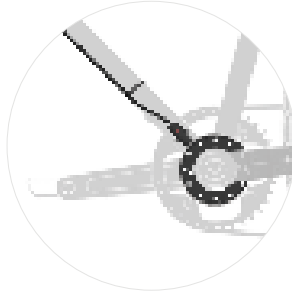

Secure the Pedal sensor cable to the underside of the bike's downtube.

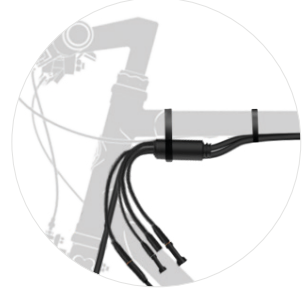

Fasten the splitter to the underside by the headtube.

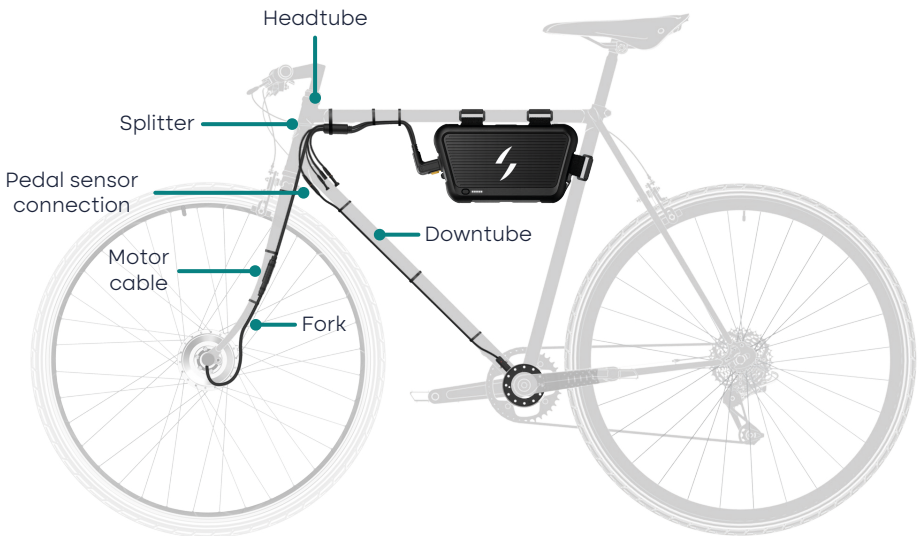

### Note

Loop any extra cable back onto itself and fasten it securely to the frame.

# 3

## Know Your Kit

Starting Your Ride

Charging

Maintenance

# Starting Your Ride

- 1.1 To start your ride first make sure all cables are connected fully and the pedal sensor has been fitted correctly.
- 1.2 Press the On/Off button on the front of the Power Pack, the LEDs should show, indicating that the power is on.
- 1.3 Start pedaling, the pedal sensor will flash and the power will begin to kick in.

## Note

If you have connected an optional display, these instructions will slightly differ. Please refer to the display manuals for more help.

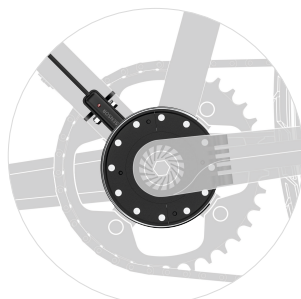

## Note

To end your ride, simply turn off your Power Pack by pressing the On/Off button.



# Charging

- 1.1 Turn your Power Pack Off.
- 1.2 Plug the charger end into the connector.
- 1.3 When the light on the charging brick changes from red to green the Power Pack is fully charged and should be unplugged.



Don't charge for extended periods of time.



Only use the charger provided to charge the battery.



If leaving your battery in storage for a long time, charge it to full beforehand and turn off the battery at the button. Please charge every 90 days to maintain the battery life.

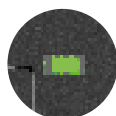
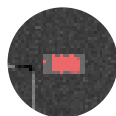

# Maintenance

Interval (whichever is first)	Swytch Kit	Bike
Every ride	<p>Recharge the Power Pack</p> <p>If installed, test the brake sensors operate normally</p>	<p>Tyre pressure</p> <p>Check tyres for debris/thorns</p> <p>Check brakes</p>
<p>Monthly</p> <p>20 hours</p> <p>500 miles</p>	<p>Top up battery charge if storing over winter</p> <p>Check motor wheel nuts are tight</p> <p>Make sure the pedal sensor is aligned</p>	<p>Adjust brakes</p> <p>Lubricate chain</p> <p>Look for tyre wear</p>
<p>6 months</p> <p>100 hours</p> <p>3000 miles</p>	<p>Test motor wheel spoke tension</p> <p>Check motor and sensor connectors</p> <p>Check throttle and pedal sensor function normally</p> <p>Inspect Power Pack for any damage</p> <p>Check straps for any damage</p>	<p>Deep clean drive parts</p> <p>Ensure that your rims are true, without any wobble</p>
<p>12 months</p> <p>200 hours</p> <p>6000 miles</p>	<p>Check motor wheel turns smoothly and quietly</p>	<p>Replace drive parts if necessary</p> <p>Regrease bearings if necessary</p>

Swytch Technology Ltd,  
Unit 2A  
455 Wick Lane  
London  
E3 2TB



Scan here for the  
Swytch Help Centre.

