

# Thumb Throttle

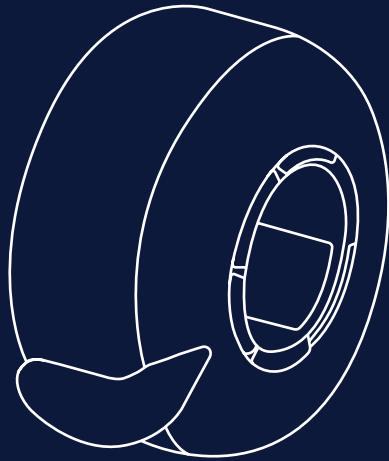

# 00

## Table of Contents

**01** About p.3

**02** Installation p.4

# 1. About

Using a throttle allows you to power the bike without pedalling, by simply twisting or pushing it to apply power.

Our throttle is compatible with all Swytch Kits and can be simply fitted by sliding onto your handlebars. They can be easily added or removed at any time. Throttles are compatible with most standard handlebars, but unfortunately, they won't fit on drop bars.

In the EU, UK, and AU, throttle functionality has been updated to comply with local regulations.

When you're not pedaling, the throttle activates in "walk mode," providing a gentle push at a speed of up to 6 km/h—perfect for starting off after stopping at a traffic light.

While pedaling, engaging the throttle boosts the motor power to PAS level 5, offering extra assistance. This is especially helpful when you're riding in a battery-saving mode (e.g. PAS level 1) and approaching an incline, providing an instant power boost when needed.



## 2. Installation

### 1. Fit the thumb throttle to the handlebars

- 1.1 The throttle should be on the right-hand side. Start off by removing your hand grips.
- 1.2 Untighten the small screw using a 2.5mm Allen key. Next, slide on the throttle. Position it correctly as shown leaving a 2mm gap between the throttle and your hand grips. and tighten the screw, securing it in place.



Check your brakes and gear shifters work as normal.



Check the throttle does not touch the hand grips.



Always fit the spacer inside of the throttle body.

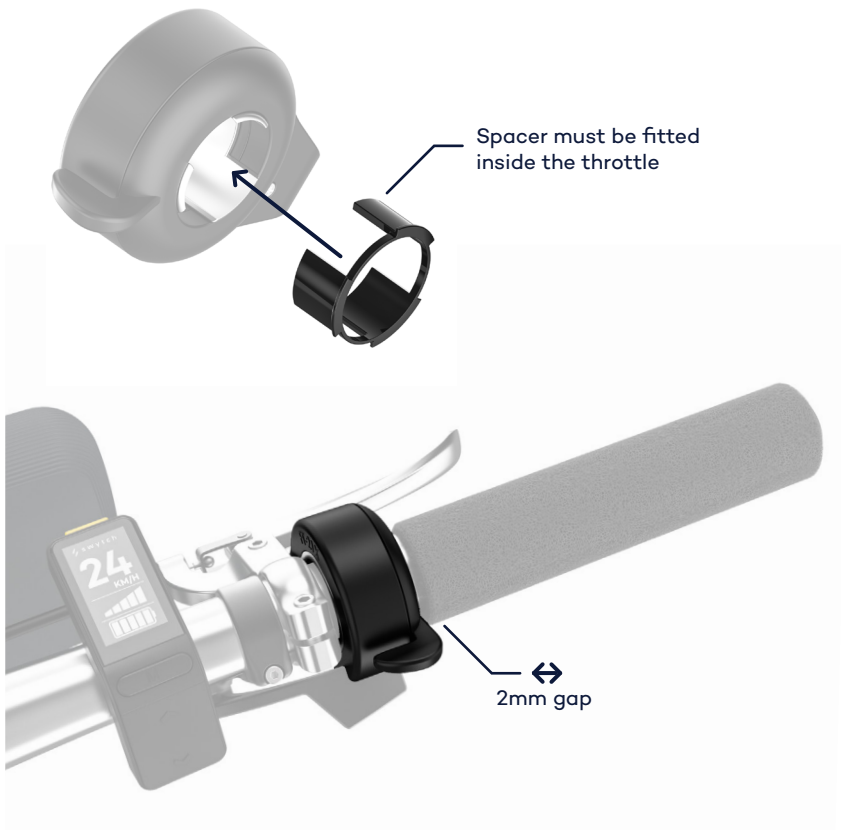

## 2. Connect the thumb throttle to the mount

- 2.1 Find the mount cable with the same coloured end as the throttle cable. The tall end fits into the short end.

Using the arrow on each connector and line them up. Once aligned, push the connector pair together until no colour is visible.

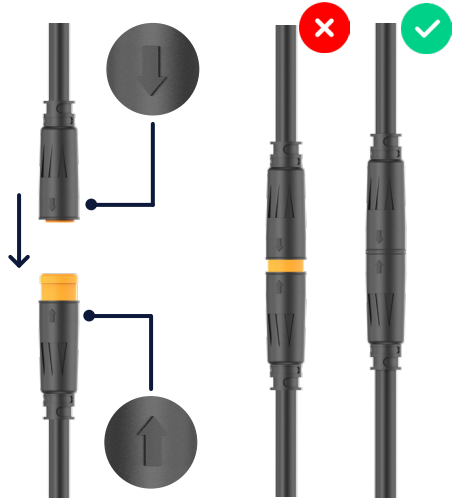

 swytch