

# Twist Throttle

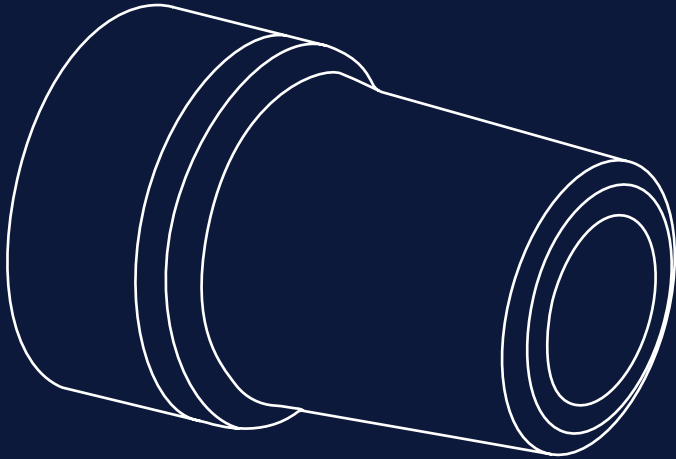

# 00

## Table of Contents

**01** About p.3

**02** Installation p.4

## 1. About

Using a throttle allows you to power your bike without pedalling, by simply twisting or pushing it to apply power. Without one, the Kit is purely a pedal-assist system. Throttles must be used off-road or on private land, as in the UK and EU, they aren't road-legal. We recommend checking your local laws.

Our throttle is compatible with all Swytch Kits and can be simply fitted by sliding onto your handlebars. They can be easily added or removed at any time. Throttles are compatible with most standard handlebars, but unfortunately, they won't fit on drop bars.



## 2. Installation

### 1. Fit the twist throttle to the handlebars

1.1 The throttle should be on the right-hand side. Remove your hand grips and cut them shorter, allowing a 2mm gap for the throttle.

1.2 Untighten the small screw using a 2.5mm Allen key. Next, slide on the throttle. Position it correctly as shown and tighten the screw, securing it in place.



Check your brakes and gear shifters work as normal.



Check the throttle does not touch the hand grips.



Always fit the spacer inside of the throttle body.

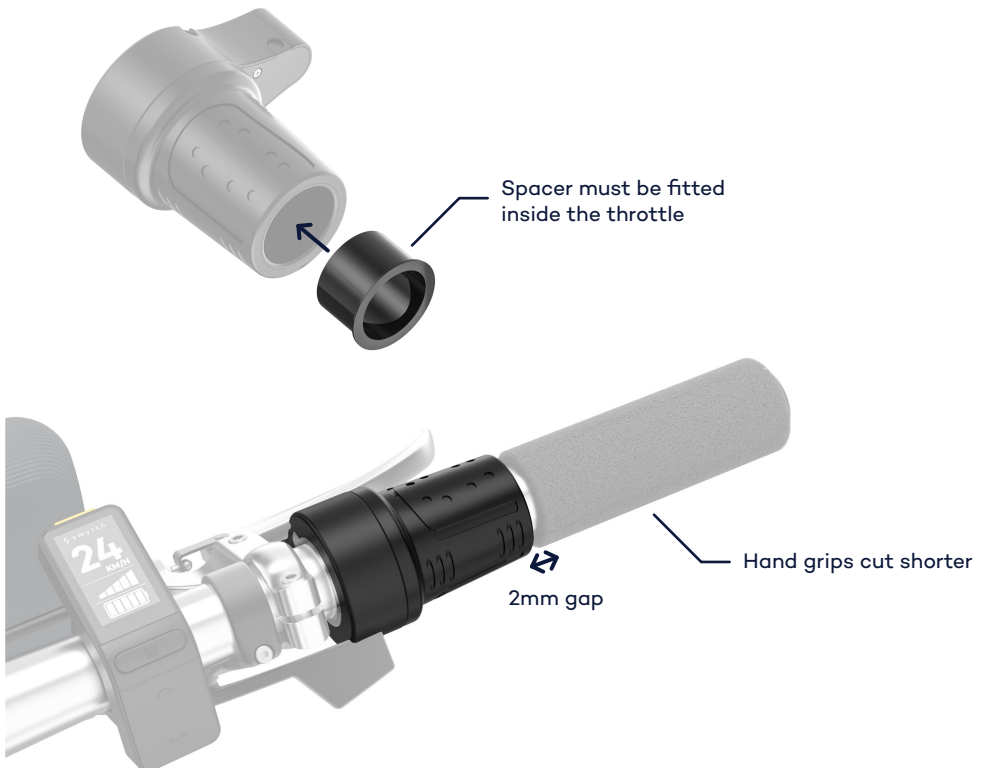

## 2. Connect the twist throttle to the mount

- 2.1 Find the mount cable with the same coloured end as the throttle cable. The tall end fits into the short end.

Using the arrow on each connector and line them up. Once aligned, push the connector pair together until no colour is visible.

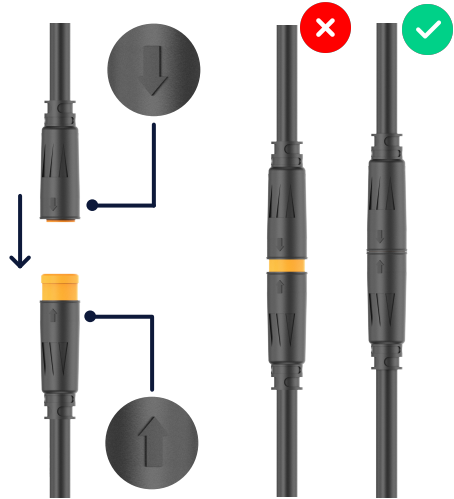

 s w y t c h